

**PK 5.001 SLD 1 | PK 5.001 SLD 3 | PK 5.501 SLD 5**

# **THE LINKAGE SYSTEM IMPROVES THE CRANE GEOMETRY**

**LIFETIME EXCELLENCE**



# OPTIMUM USE OF PAYLOAD

- Shorter load cycle times due to High Speed Extension
- Perfect appearance and extremely high value retention thanks to coating technology
- Maximum utilisation of the working range thanks to extended HPSC
- Higher payloads due to intelligent lightweight design





# ABILITY TO WORK EFFICIENTLY AT THE HIGHEST LEVEL

## 9 Highlights



### Single Link

More power on the hook

The knuckle joint significantly improves the crane's motion geometry.



### High Speed Extension

For efficient assignments

The High Speed Extension speeds up the extension boom system. Crane works faster and more efficiently.



### Coating technology

Top quality surface protection at a glance

The KTL coating lays the foundation for a perfect surface protection. Afterwards the components are either coated in the powder-coating facility or are finished with a two-components-topcoat. High value retention and excellent corrosion protection for the whole life of a crane.

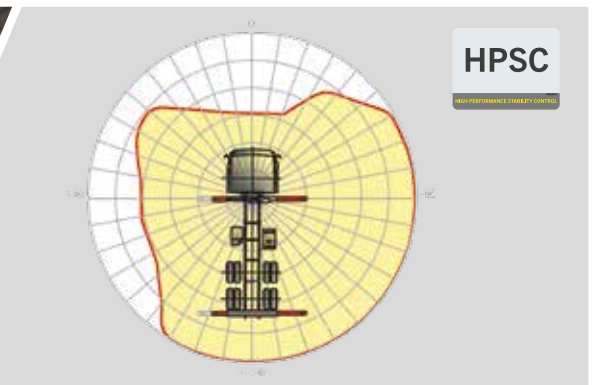

### HPSC\*

Maximum utilisation of the working range

The variable stabiliser positioning of the High Performance Stability Control System allows the full lifting capacity of the crane to be used, even when working within tight spaces.



**Paltronic\***

Comfort and safety

The PALTRONIC, PALFINGER offers the latest control electronics for the series production crane. The custom designed electronic operates and monitors the crane and offers more efficiency in use and safety.

**Radio remote control\***

Dialogue with the operator

PALFINGER radio remote controls are equipped with linear lever or cross lever and provide the greatest possible comfort for the operator. All SLD 5 models with LED-Display inform the crane operator about the different operating conditions.



**Hose equipment for attachments\***

Enhances versatility

The hose equipment offers an easy means of connecting auxiliary equipment. The hose equipment is guided in hose trays for protection.

**Lighting package\***

More crane safety particularly at dusk and dark

LEDs which backlight the control panel make it easier to read off the crane functions and provide the crane operator with a quick overview of the entire panel during the working process. LED warning lights in the supporting cylinders mean greater safety for crane operator and passers-by.



**Control console**

All information at a glance

All important information about the crane can be seen on the main control stand. A digital indicator counts and displays the operating hours. Ergonomic control levers and the optional lighting package provide increased safety and comfort even in poor visibility conditions.

# PK 5.001 SLD 1 (NON-CE)

## PERFECT DIMENSIONS

**STD**

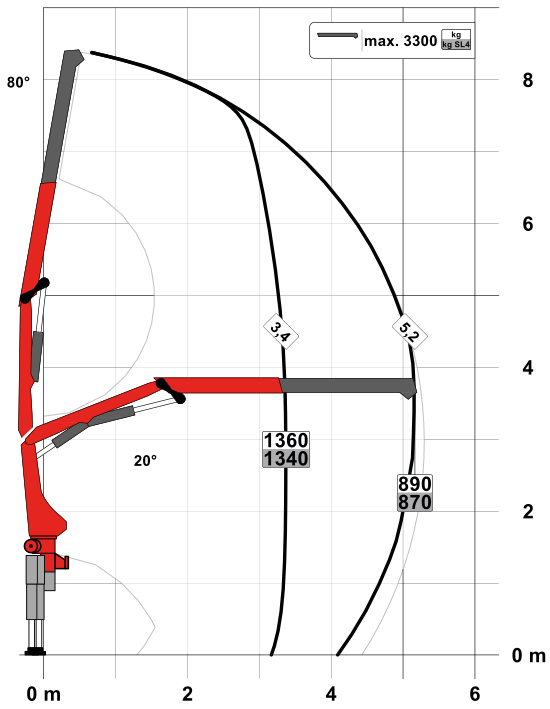

**A**

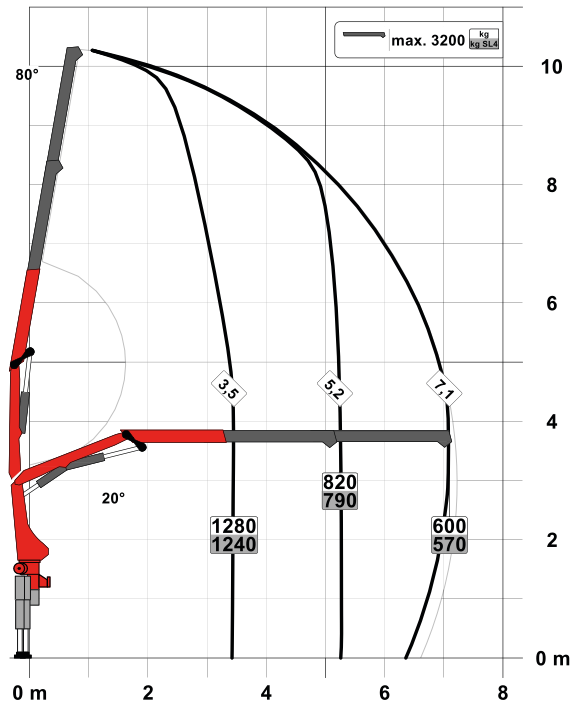

**C**

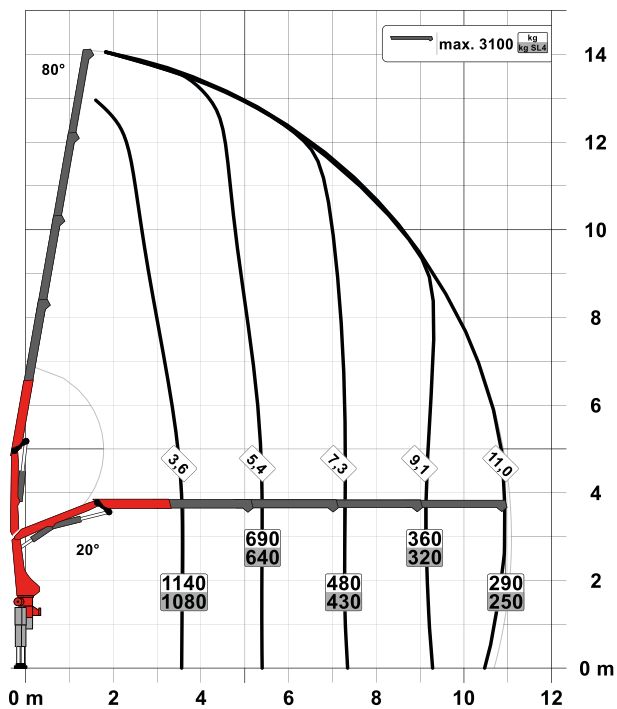

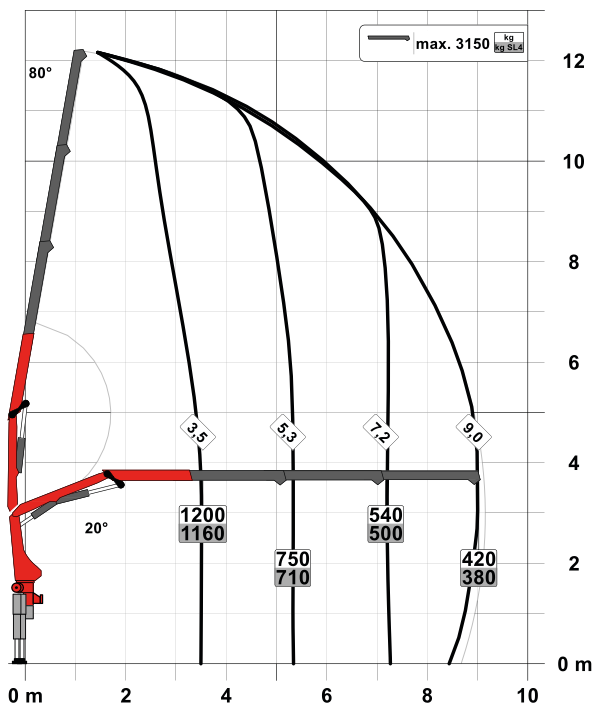
**B**

## SLD 1 (NON-CE)

- Single Link
- Optional:
  - Overload protection OSK
  - Radio remote control
- NON-CE mode

## Technical specifications

### EN 12999 HC1 HD4/S2

Max. lifting moment	4.6 mt/45.0 kNm	33,190 ft.lb
Max. lifting capacity	3300 kg/32.4 kN	7,300 lb
Max. hydraulic outreach	11.1 m	36' 5"
Max. manual outreach	12.7 m	41' 8"
Slewing angle	400°	
Slewing torque	0.6 mt/5.9 kNm	4,350 ft.lb
Stabiliser spread (std./max.)	2.9 m / 5.0 m	9' 6" / 16' 3"
Fitting space required (std.)	0.66 m	2' 2"
Width folded	2.10 m	6' 11"
Max. operating pressure	330 bar	4,785 psi
Recommended pump capacity	from 15 l/min to 25 l/min	4.0 US gpm 6.6 US gpm
Dead weight (std.)	695 kg	1,530 lb

PK 5.001 SLD 3

# PERFECT DIMENSIONS

STD

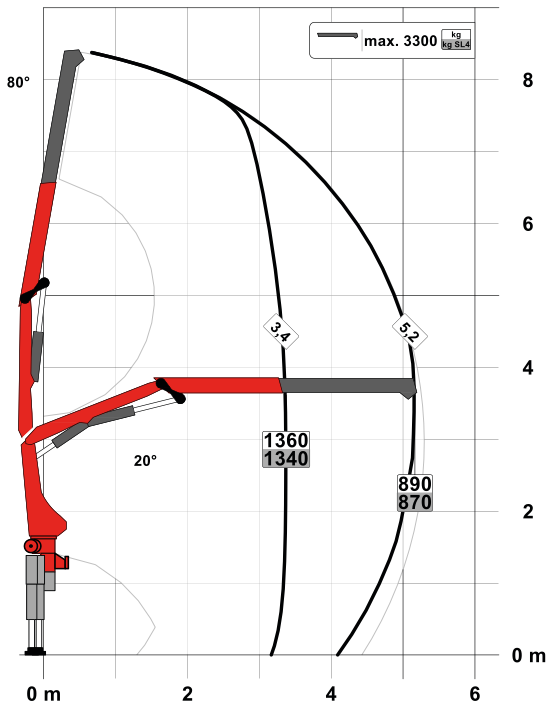

A

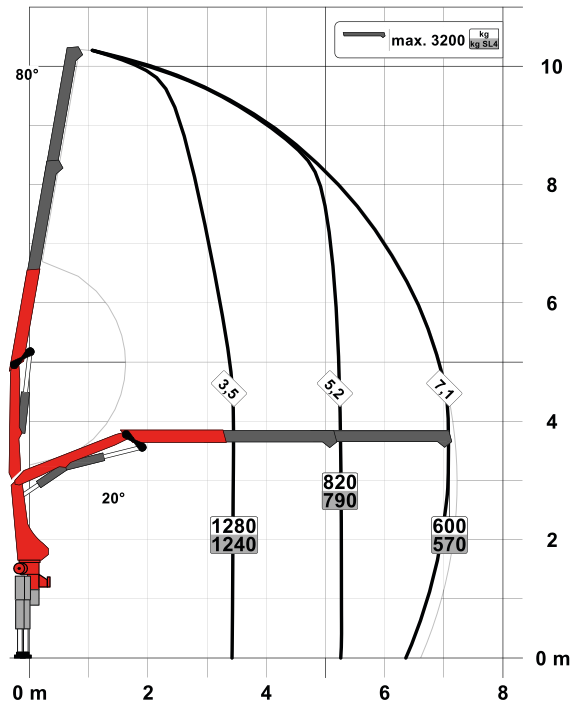

C

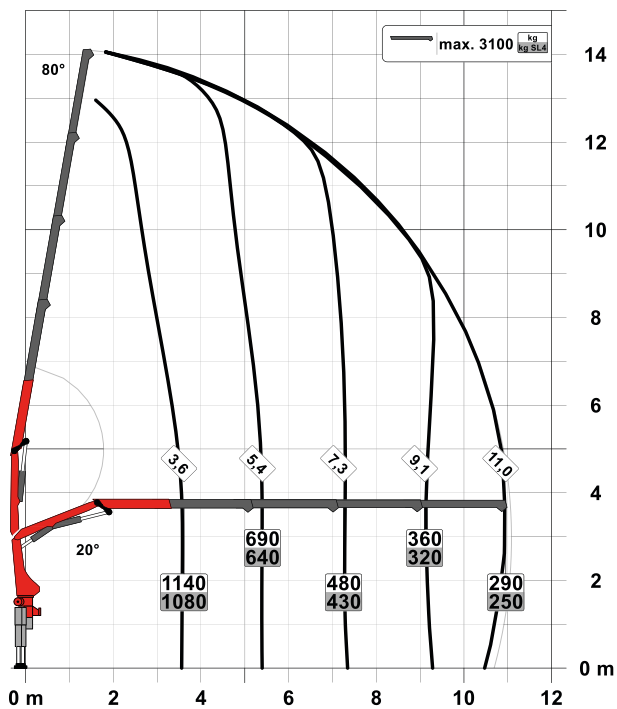

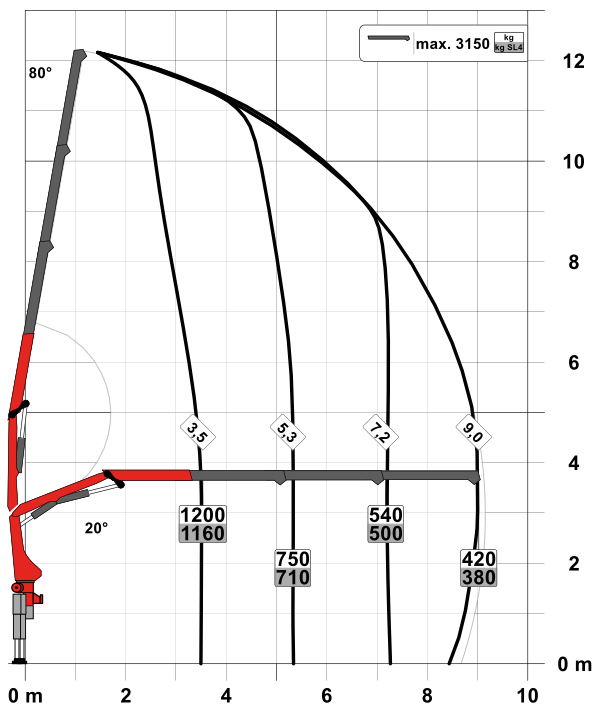
**B**

### SLD 3

- Single Link
- Paltronic overload protection
- Optional:
  - Stability monitoring system ISC-S (standard for CE), HPSC-L, HPSC-E
  - Radio remote control
- NON-CE and CE model

### Technical specifications

#### EN 12999 HC1 HD4/S2

Max. lifting moment	4.6 mt/45.0 kNm	33,190 ft.lb
Max. lifting capacity	3300 kg/32.4 kN	7,300 lb
Max. hydraulic outreach	11.1 m	36' 5"
Max. manual outreach	12.7 m	41' 8"
Slewing angle	400°	
Slewing torque	0.6 mt/5.9 kNm	4,350 ft.lb
Stabiliser spread (std./max.)	2.9 m / 5.0 m	9' 6" / 16' 3"
Fitting space required (std.)	0.66 m	2' 2"
Width folded	2.10 m	6' 11"
Max. operating pressure	330 bar	4,785 psi
Recommended pump capacity	from 15 l/min to 25 l/min	4.0 US gpm to 6.6 US gpm
Dead weight (std.)	695 kg	1,530 lb

PK 5.501 SLD 5

# PERFECT DIMENSIONS

STD

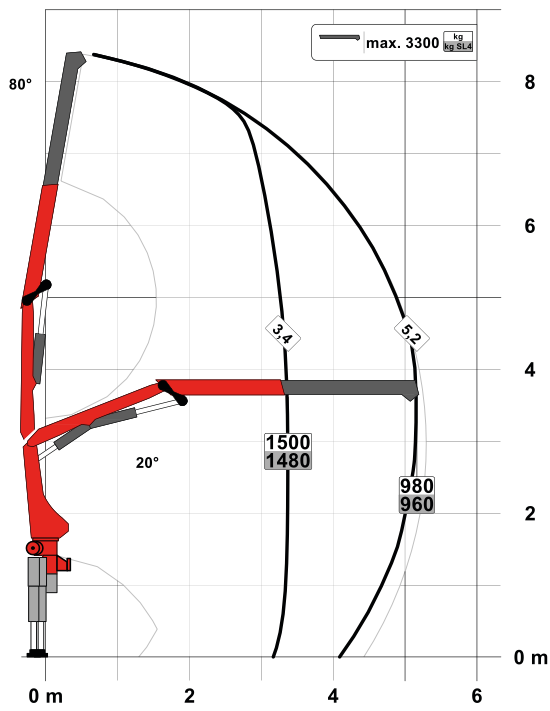

A

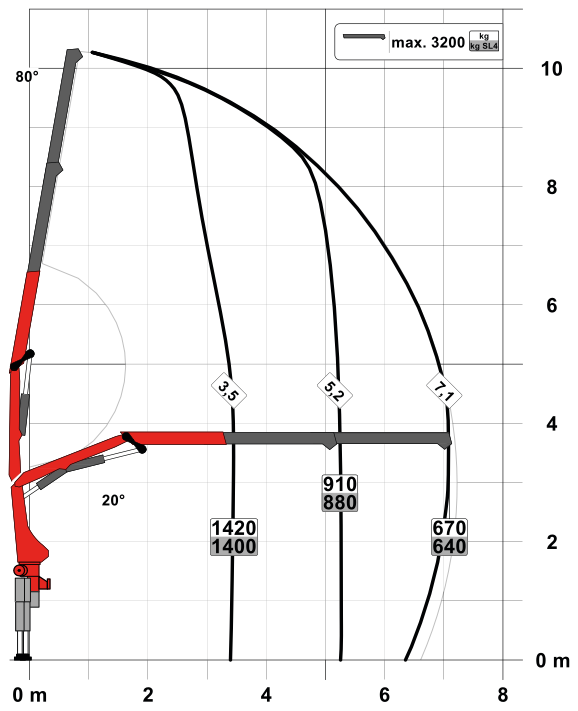

C

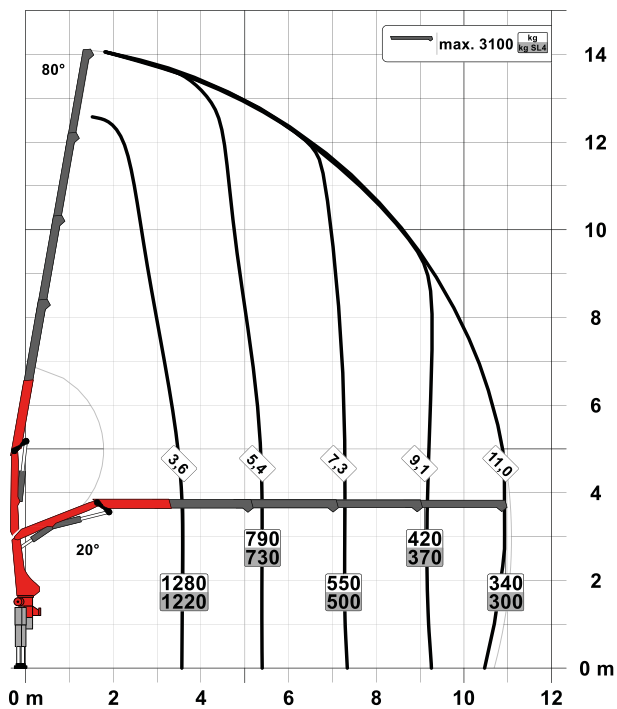

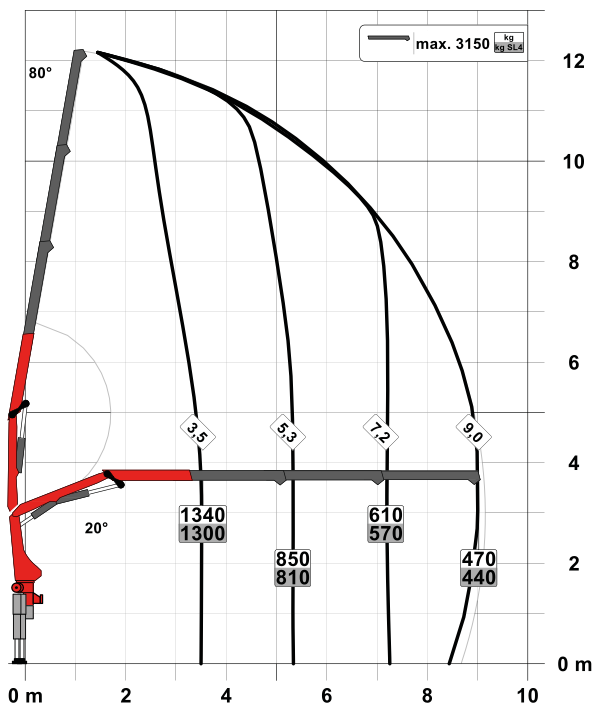
**B**

## SLD 5

- Single Link
- Paltronic overload protection
- E-HPLS
- Load Sensing valve
- Radio remote control with LED display
- Optional:
  - Stability monitoring system ISC-S (standard for CE), HPSC-L, HPSC-E
- NON-CE and CE model

## Technical specifications

### EN 12999 HC1 HD4/S2

Max. lifting moment	5.1 mt/49.8 kNm	36,730 ft.lb
Max. lifting capacity	3300 kg/32.4 kN	7,300 lb
Max. hydraulic outreach	11.1 m	36' 5"
Max. manual outreach	12.7 m	41' 8"
Slewing angle	400°	
Slewing torque	0.6 mt/5.9 kNm	4,350 ft.lb
Stabiliser spread (std./max.)	2.9 m / 5.0 m	9' 6" / 16' 3"
Fitting space required (std.)	0.66 m	2' 2"
Width folded	2.10 m	6' 11"
Max. operating pressure	360 bar	5,220 psi
Recommended pump capacity	from 20 l/min to 30 l/min	5.3 US gpm to 7.9 US gpm
Dead weight (std.)	725 kg	1,600 lb

**DIMENSIONS**

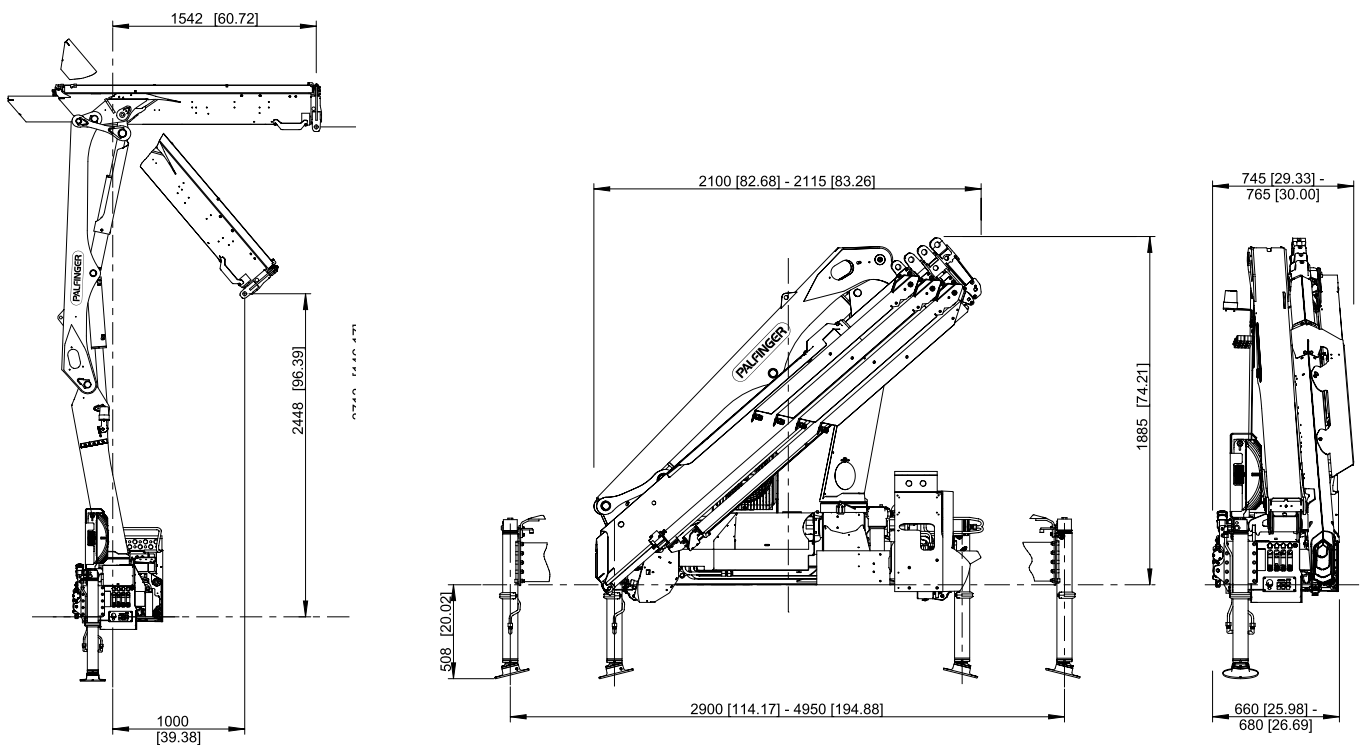

KP-PK5/55SLDM3+EN

Cranes shown in the leaflet are partially optional equipped and do not always correspond to the standard version. Country-specific regulations must be observed. Dimensions may vary. Subject to technical changes, errors and translation mistakes.